

## CDI50 Regular Contact Points

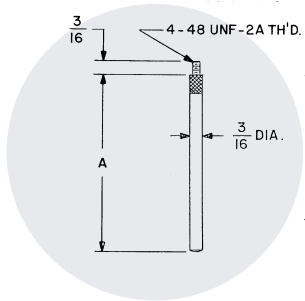

Regular Contact Points are made from hardened steel with polished tip to prevent scratching. Threads are AGD standard 4-48, 3/16" diameter.

PART #	DIM "A"	PART #	DIM "A"
CDI50125	1/8"	CDI501750	1 3/4"
CDI50250	1/4"	CDI502	2"
CDI50375	3/8"	CDI502250	2 1/4"
CDI50500	1/2"	CDI502500	2 1/2"
CDI50625	5/8"	CDI502750	2 3/4"
CDI50750	3/4"	CDI503	3"
CDI50875	7/8"	CDI503250	3 1/4"
CDI501	1"	CDI503500	3 1/2"
CDI501250	1 1/4"	CDI503750	3 3/4"
CDI501500	1 1/2"		

## CDI52 Tapered Contact Points

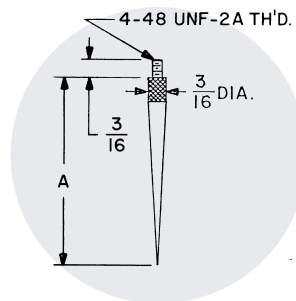

Supplied in four convenient lengths with standard AGD 4-48 thread, 3/16" diameter.

PART #	DIM "A"
CDI524062	13/32"
CDI521	1"
CDI521500	1 1/2"
CDI522	2"

## CDI53 Button Contact Points

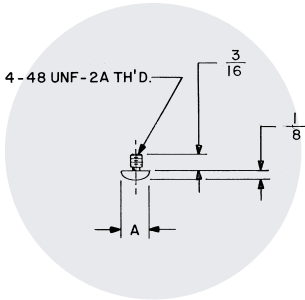

Available in 3 diameters with AGD standard 4-48 thread.

PART #	DIM "A"
CDI5337	3/8" dia.
CDI5350	1/2" dia.
CDI5375	3/4" dia.

## CDI54 Flat Contact Points

3/16" diameter with flat contact area, standard AGD 4-48 thread.

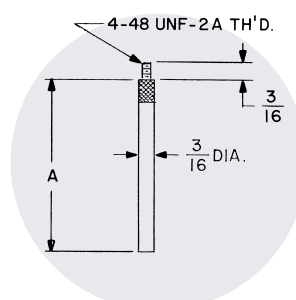

PART #	DIM "A"
CDI54125	1/8"
CDI54250	1/4"
CDI54375	3/8"
CDI54500	1/2"
CDI54625	5/8"
CDI54750	3/4"
CDI54875	7/8"
CDI541	1"
CDI541250	1 1/4"
CDI541500	1 1/2"
CDI541750	1 3/4"
CDI542	2"

## CDI82 Rack Extension

Used to extend the length of rack, for longer reach.

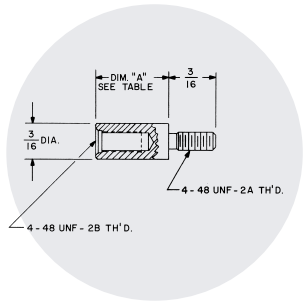

PART #	DIM "A"	PART #	DIM "A"
CDI82250	.250"	CDI821750	1.750"
CDI82375	.375"	CDI822	2"
CDI82500	.500"	CDI822250	2.250"
CDI82625	.625"	CDI822500	2.500"
CDI82750	.750"	CDI822750	2.750"
CDI82875	.875"	CDI823	3"
CDI821	1"	CDI824	4"
CDI821175	1.175"	CDI825	5"
CDI821250	1.250"	CDI826	6"
CDI821375	1.375"	CDI827	7"
CDI821500	1.500"	CDI828	8"
CDI821575	1.575"		

## CDI55 Wide Face Flat Contact Points

3/32" thick with beveled edges, standard AGD 4-48 thread.

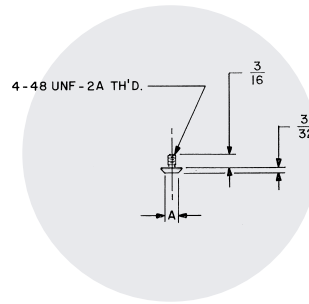

PART #	DIM "A"
CDI5525	0.250 Sq." Cont. area
CDI5537	0.375 Sq." Cont. area
CDI5550	0.500 Sq." Cont. area
CDI5562	0.625 Sq." Cont. area

## CDI Spindle Converter M00-0020 Inch to Metric M00-0022 Metric to Inch

